

6

5

4

3

2

1

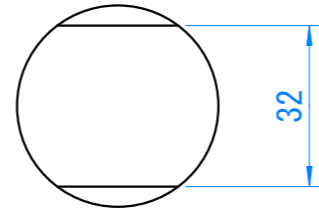
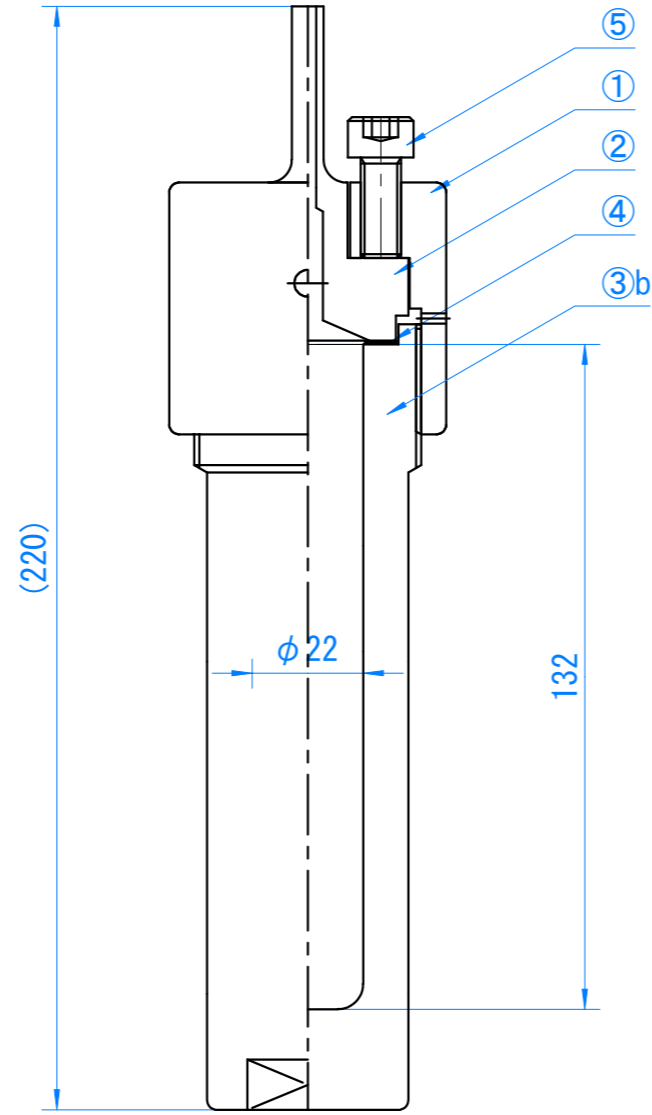
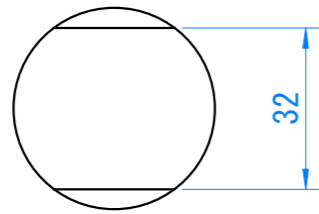
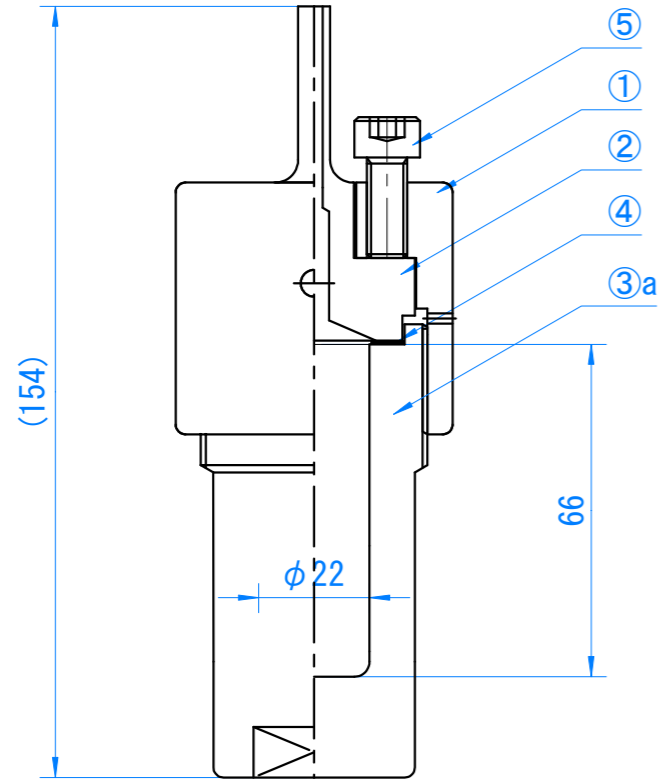
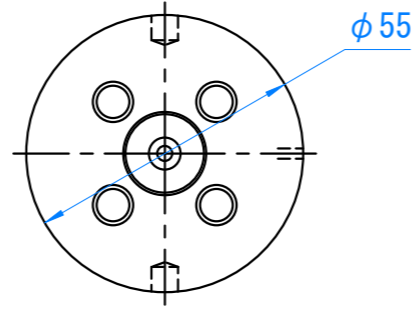
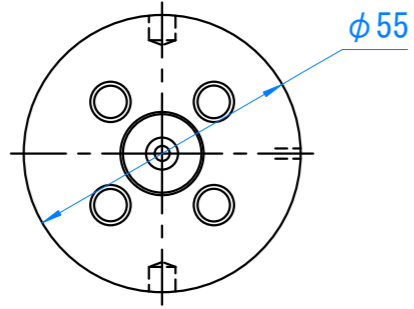

No.	Name	Material		Parts number	
①	Screw cap	SUS316	1	HMS-2550CAP	
②	Plate with nozzle	SUS316	1	HMS-2550NCAP	OD1/4in(ID3.4mm)
③a	Vessel body	SUS316	1	HMS-25BD	
③b	Vessel body	SUS316	1	HMS-50BD	
④	Gasket	Ni	1	HMS-2550NI	
④	Gasket	Cu	1	HMS-2550CU	
④	Gasket	PTFE	1	HMS-2550TF	
⑥	Bolt	SCM435	4	HMS-2550SC	M8 hexagon socket head bolt

Maximum temperature	300 °C (PTFE gasket: 200 °C)
Maximum pressure	20 MPa
Volume	25 ml / 50 ml approx.
Weight	1.5 kg / 1.9 kg approx.

[mm]

SAN-AI KAGAKU CO.,LTD.

TITLE
High pressure vessel
Model: HMS-25 / HMS-50

SIZE	CAGE CODE	DWG NO	REV
A3		20220518	
SCALE	1:1		SHEET

6

5

4

3

2

1