

6

5

4

3

2

1

| No. | PARTS NAME | MATERIAL | | PARTS NUMBER |
|-----|----------------------------|----------|---|----------------------------|
| ① | Center Screw | SUS316L | 1 | HUS-***CS (HEX 19:AB 24:C) |
| ② | Screw Cap | SUS304 | 1 | HUS-***CAP |
| ③ | Top Plate | SUS304 | 1 | HUS-***UP |
| ④ | PTFE Cap | PTFE | 1 | HUT-***CAP |
| ⑤ | PTFE Bottle (Plane bottom) | PTFE | 1 | HUT-***BD |
| ⑥ | PTFE Bottle (Round bottom) | PTFE | 1 | HUT-***RBD |
| ⑦ | Cylinder | SUS304 | 1 | HUS-***BD |
| ⑧ | Bottom Plate | SUS304 | 1 | HUS-***BP |
| ⑨ | * | * | * | * |
| ⑩ | * | * | * | * |
| ⑪ | * | * | * | * |
| ⑫ | * | * | * | * |
| ⑬ | * | * | * | * |
| ⑭ | * | * | * | * |
| ⑮ | * | * | * | * |
| ⑯ | * | * | * | * |
| ⑰ | * | * | * | * |
| ⑱ | * | * | * | * |
| ⑳ | * | * | * | * |

Model HU-25: A
 Model HU-50: B
 Model HU-100: C

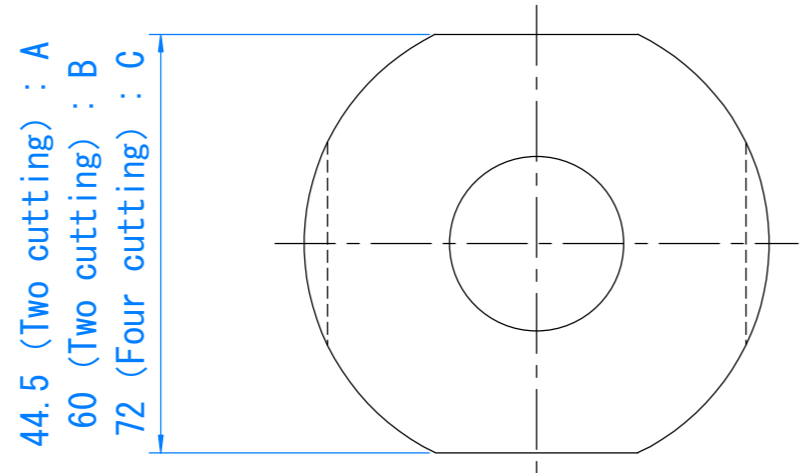
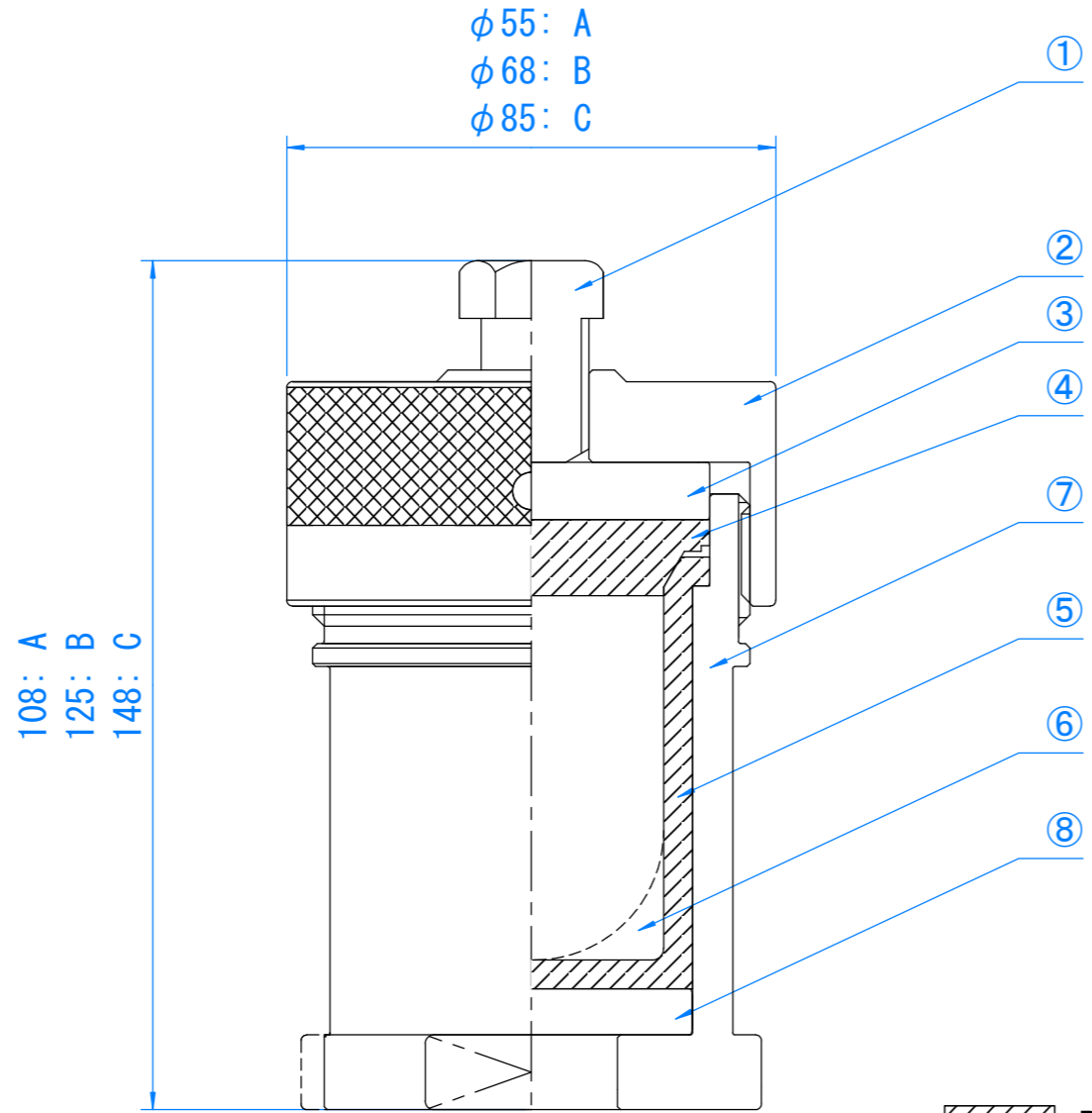

| | |
|---------------------|-----------------------------|
| Maximum temperature | 230 °C |
| Maximum pressure | 15 MPa |
| Volume | 25/ 50/ 100 ml approx. |
| Weight | 980/ 1,720/ 2,990 g approx. |

[mm]

SAN-AI KAGAKU CO.,LTD.

| | | | |
|---|-----------|----------|-----|
| TITLE | | | |
| Model: HU series Sealed Decomposition Vessel | | | |
| SIZE | CAGE CODE | DWG NO | REV |
| A3 | | 11. 2023 | |
| SCALE | | SHEET | |

6

5

4

3

2

1