

6

5

4

3

2

1

No.	PARTS NAME	MATERIAL	QTY	PARTS NUMBER
①	Center Screw	SUS304	1	HUS-100CS
②	Screw Cap	SUS304	1	RDVS-100CAP
③	Top Plate	SUS304	1	HUS-100UP
④	PTFE Cap	PTFE	1	HUT-100CAP
⑤	PTFE Bottle	PTFE	1	RDVT-250BD
⑥	Cylinder	SUS304	1	RDVS-250BD
⑦	Bottom Plate	SUS304	1	HUS-100BP
⑧	*	*	*	*
⑨	*	*	*	*
⑩	*	*	*	*
⑪	*	*	*	*
⑫	*	*	*	*
⑬	*	*	*	*
⑭	*	*	*	*
⑮	*	*	*	*
⑯	*	*	*	*
⑰	*	*	*	*
⑱	*	*	*	*
⑳	*	*	*	*

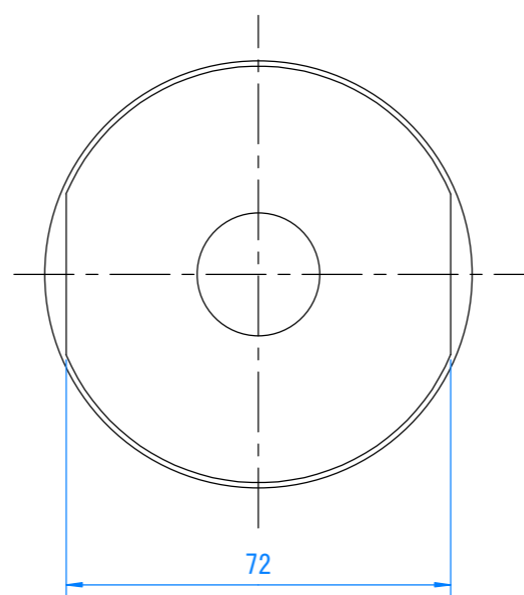
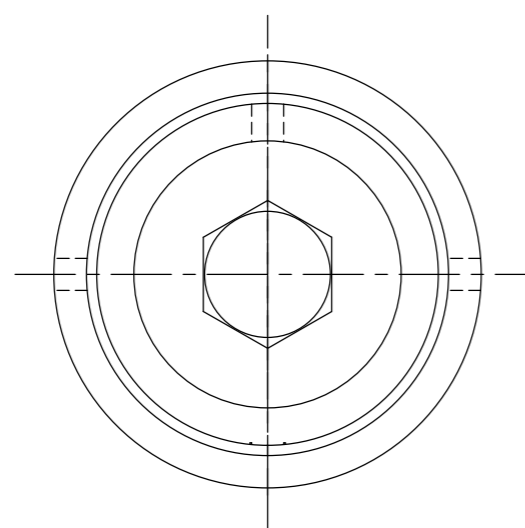
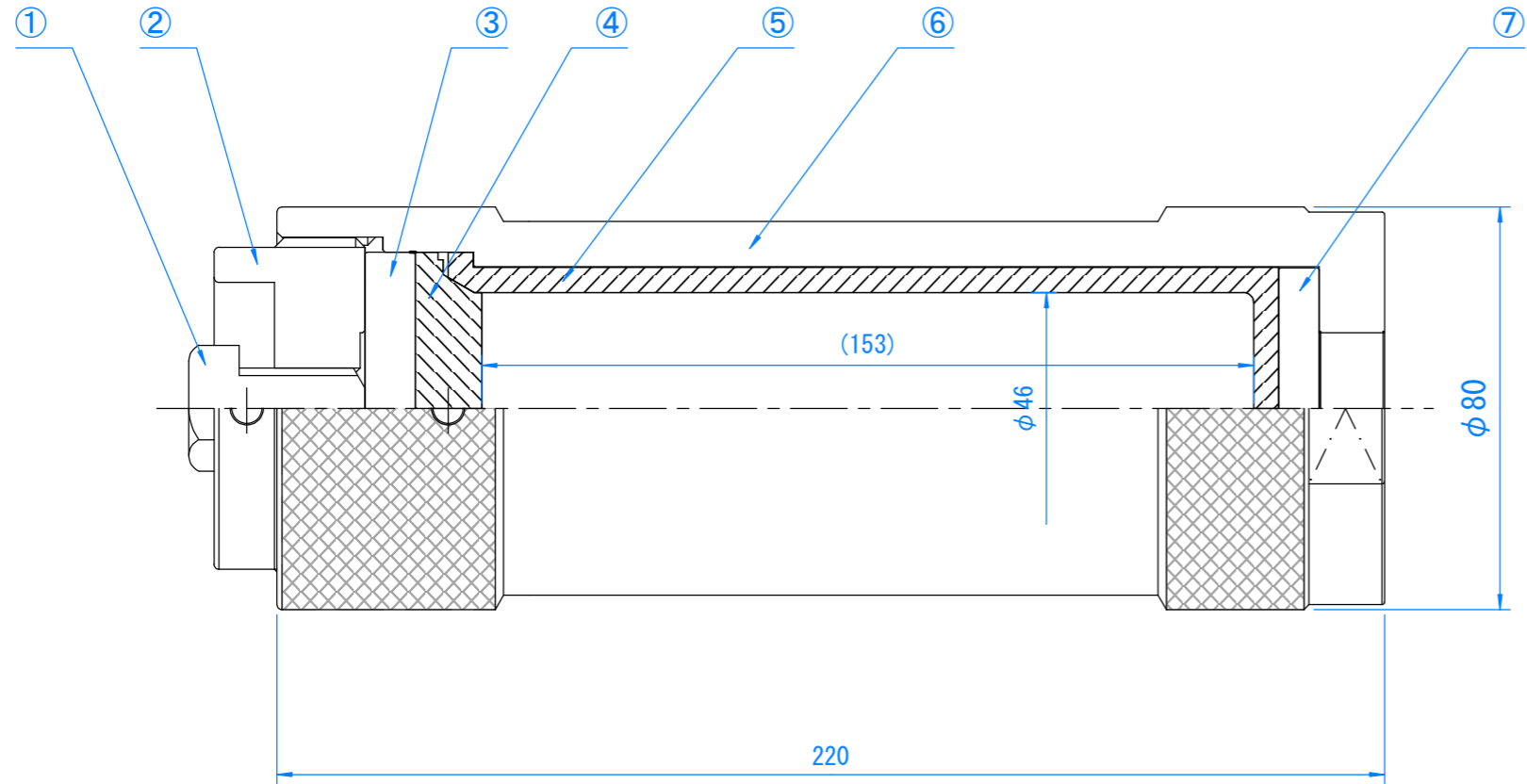

[mm]

Maximum Temperature	230 °C
Maximum Pressure	10 MPa
Capacity	250 ml approx.
Weight	4,956 g

SAN-AI KAGAKU CO.,LTD.			
TITLE Model: RDV-250 Sealed Decomposition Vessel (Rotary type)			
SIZE A3	CAGE CODE	DWG NO	REV
SCALE		SHEET	

6

5

4

3

2

1