

6

5

4

3

2

1

No.	PARTS NAME	MATERIAL	QTY	PARTS NUMBER
①	Center Screw	SUS304	1	HUS-100CS
②	Screw Cap	SUS304	1	RDVS-100CAP
③	Top Plate	SUS304	1	HUS-100UP
④	PTFE Cap	PTFE	1	HUT-100CAP
⑤	PTFE Inner Vessel_body	PTFE	1	RDVT-250BD
⑥	Cylinder	SUS304	1	RDVS-250BD
⑦	Bottom Plate	SUS304	1	HUS-100BP
⑧	Detachable Handle	SUS304	1	*
⑨	*	*	*	*
⑩	*	*	*	*
⑪	*	*	*	*
⑫	*	*	*	*
⑬	*	*	*	*
⑭	*	*	*	*
⑮	*	*	*	*
⑯	*	*	*	*
⑰	*	*	*	*
⑱	*	*	*	*
⑳	*	*	*	*

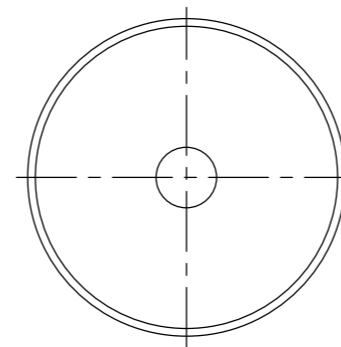
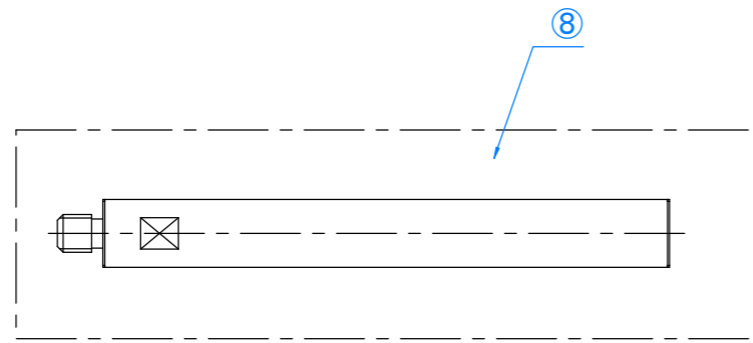
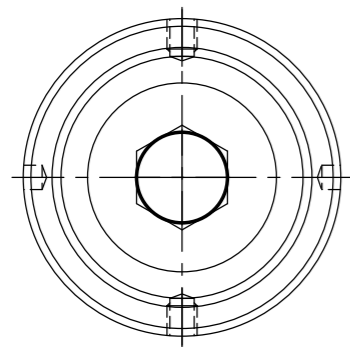
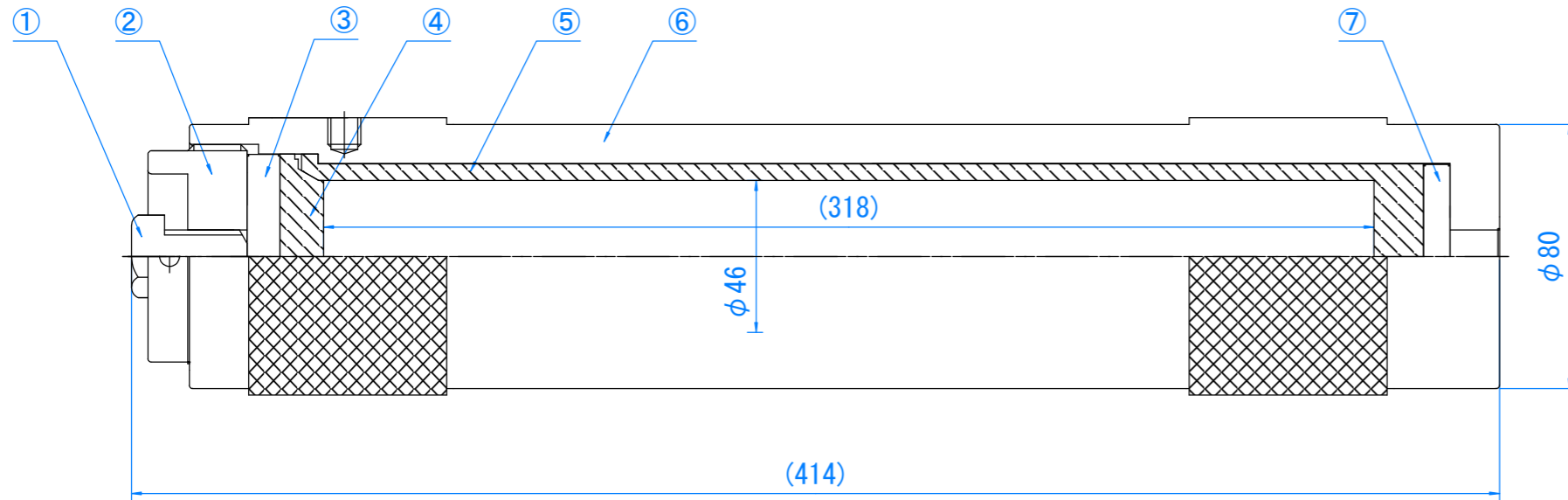

Maximum Temperature	200 °C
Maximum Pressure	4.5 MPa
Capacity	530 ml approx.
Weight	10 kg approx.

[mm]

**SAN-AI KAGAKU CO.,LTD.**

TITLE  
**Model: RDV-L320**  
**Rotary Sealed Decomposition Vessel**

SIZE <b>A3</b>	CAGE CODE	DWG NO	REV
SCALE			SHEET

6

5

4

3

2

1